

Flexible Bag Collator

NEW and Innovative
Patent pending



Rotopack Product Collator

Features:

Rotopack

- Collate regularly up to **120 bags per minute**
- Operates both **Continuous and Intermittent**
- Interchangeable divider rack
- **No limit to product type and size**
- Change over time in a minute
- **Use with VFFS, HFFS or other**
- Product handling made easy

Modular Conveyor

- Z-Shape configuration
- Adjustable angle 15-45 degrees
- Polycarbonate safety guard
- Drop chute
- Stainless Steel construction
- Variable speed
- Belt width 356mm

Why do I need the Rotopack

1. Increase in competition demands new technology
2. Capitalise on your invested equipment (i.e. Bagger and Linear weigher)
3. Increase your production speed
4. Increase profits
5. Reduces labour cost on output performance
6. Trim the fat off your production
7. Maintain current floor space (real estate efficient)

MADE IN AUSTRALIA

ADM
PACKAGING
TECHNOLOGY

Specification

Rotopack RPK 5A

- Stainless Steel carasel
- LCD touch screen
- Collative adaptive speed sync
- Fault detection system
- Low maintenance
- 1400mm dia top
- Adjustable support tray
- Safety stall power limit
- 6 bar air
- 110 / 240 Vac Power supply (1000 watts)



Optional: Semi Automatic Case Erector

- Single lane
- Dual lane

Patent Pending

Aust APP No: 2007902256

Request a video

Types of products

- Pillow packs
- Gusseted bags
- Standu pouch
- Satchet
- Cookie wraps
- Injection moulded parts

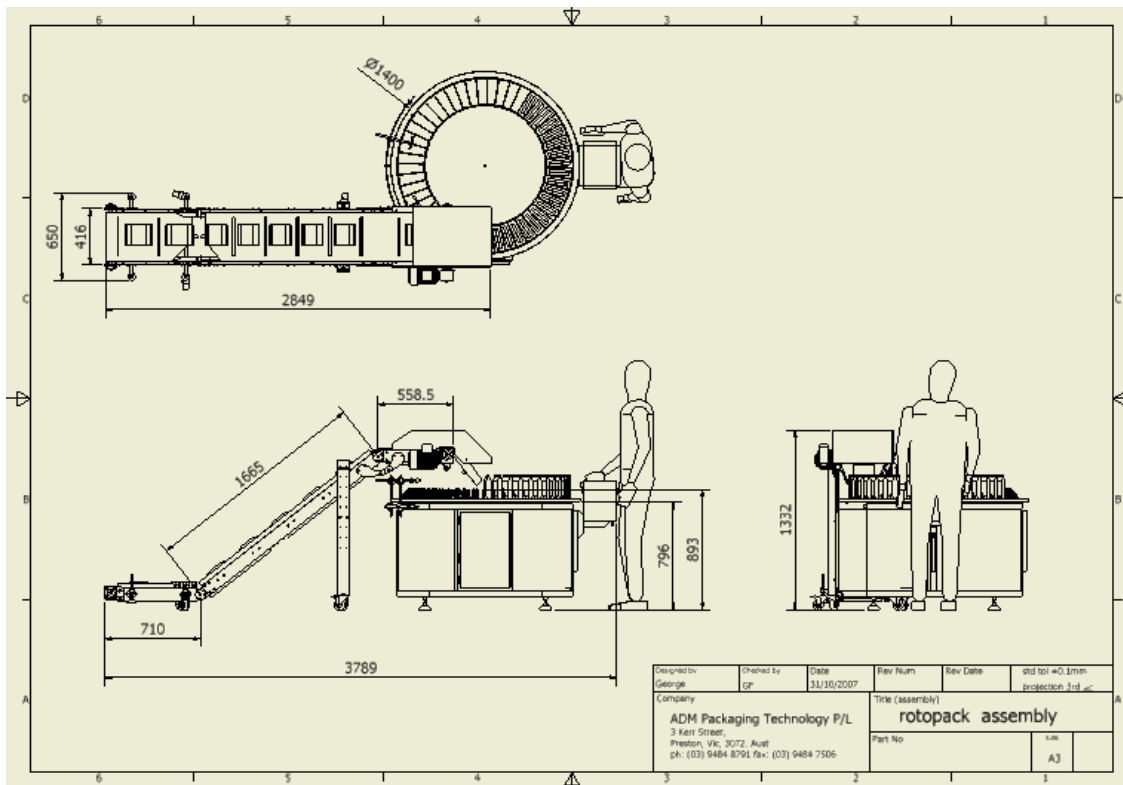

Manufactured by:

ADM Packaging Technology

3 Kerr Street, Preston, Vic, 3072, Australia

Ph: +61 3 94848791 Fax: +61 3 9484 7506

Email: info@admpt.com.au

Website: www.admpt.com.au

Distributor/ Partner: