

## VERTICAL FORM FILL & SEAL

Take advantage of the LAV-3 High Speed Labeller and cut your production costs for good. In this configuration the labeller blows the labels onto flexible bags formed on a Vertical Form Fill and Seal machine for both intermittent and continuous motion applications.

The on-line labeller uses a narrow arm that slides behind a feedtube of the bag forming tool and is placed in position ready to apply labels.

The speed of the bagmaker is unaffected as each label is fired onto its target with close range accuracy for each signal.

The placement of labels occurs after the bag is formed and before the product is dumped. This allows the labels to stick directly onto the flexible bag using the feedtube as solid back reinforcement.

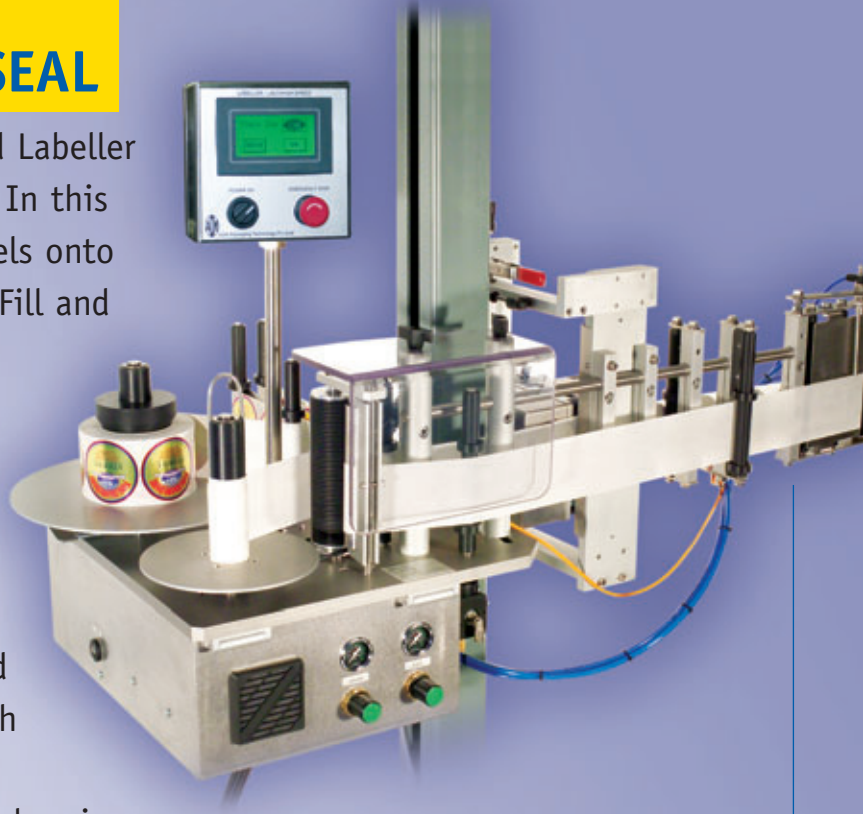

# LAV3

# HIGH SPEED LABELLER

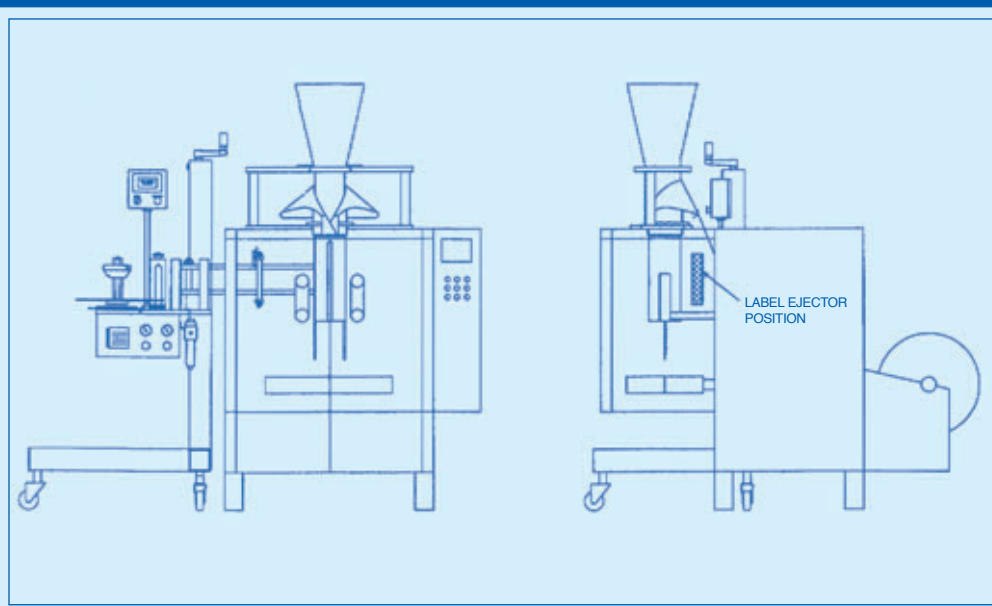

## TYPICAL LABELS

- Pre-printed labels
- Print & Apply
- Re-sealable tab inserts
- Promotions
- Nutritional information

[www.admpt.com.au](http://www.admpt.com.au)

**ADM**  
PACKAGING  
TECHNOLOGY

MADE IN AUSTRALIA

# LAV3 HIGH SPEED LABELLING SOLUTIONS



## FEATURES

- LCD touch screen
- Full diagnostics
- Counter control
- Label size inputs
- Label empty detection
- Advanced Technology Motor
- Industrial heavy duty
- Stainless Steel/Aluminium construction
- Low friction rollers
- User friendly operator interface

## TYPICAL APPLICATIONS

- VFFS&HFFS
- CARTONERS
- VACUUM SEALERS
- IN-LINE CONVEYORS
- TRAYS
- CONTAINERS
- BOTTLES
- CUSTOM DESIGNS

## OPTIONS

- Vacuum/Eject
- Wipe on
- Roll on
- Hot foil printers
- Thermal transfer printers
- Right or left-hand version
- Mobile stand
- Pick & place
- Missing imprint detection on label
- Higher Speeds

## SPECIFICATIONS: LAV3

Speed	Blow on 90+ labels/min (optional 180+ labels/min) Apply on 150+ labels/min.
Label Dimension	<ul style="list-style-type: none"><li>• 150mm high x up to 250mm wide (max)</li><li>• Custom sizes available</li></ul>
Roll Size	300mm o/d + core size 65mm-95mm i/d
Label Gap	3mm average
Label Sensing	Photo electric
Linear Speed	30m/min (optional 60m/min)
Accuracy	±0.25mm
Air Consumption	60-120l/min @ 3-6 bar (blow on)
Power Supply	115/240Volt AC @ 3amps



[www.admpt.com.au](http://www.admpt.com.au)

**ADM**  
PACKAGING  
TECHNOLOGY

3 KERR STREET, PRESTON, 3072, VICTORIA, AUSTRALIA  
T: +61(03) 9484 8791 F: +61(03) 9484 7506  
EMAIL: [info@admpt.com.au](mailto:info@admpt.com.au)

MADE IN AUSTRALIA